

Membership Documentation



*The*  
**UNITED  
WAYFARERS  
CLUB**



**REFUEL . REPAIR . REARM**

## YOUR PASSPORT TO PEACE OF MIND:



No matter how dire your situation, with this card, you can rest assured that help is on the way. From the heart of the UEE to the far corners of the fringe, the United Wayfarers Club is there for pilots in need of speedy, reliable service with a smile. From emergency assistance, comprehensive travel services, and navigational support to member discounts and touring tips, the UWC has you covered.

Although your biometric signatures are used for primary identification, this unique card serves as an alternative validation method to Club services, for use in less developed parts of the universe.

## WELCOME

Dear Member,

Congratulations! You can now sit back and enjoy the ride, safe in the knowledge that we have you covered for another year.

As a member, you'll enjoy our award-winning emergency assistance program as well as a wide array of travel services and benefits available throughout the 'verse. No matter what system you're traversing, the UWC is there to provide support on the fly, either directly through our network of franchised service stations, or via our roster of certified repair associates.

When you're in The Club, we've got your back.

## WHEREVER YOU GO, THERE WE ARE

The UWC represents the largest network of repair specialists and service stations in the universe, boasting representation across the UEE and beyond. In recent years, they have even brought a handful of Banu and Xi'an clubs into the fold, expanding the reach of member services and ensuring safe travel for all Club members, no matter how far from home they may find themselves.

Since 2473, the UWC has been synonymous with comprehensive aid and support for pilots and travelers of every ilk. For centuries, UWC contractors have come to rely on Aegis Dynamics to get the job done. The famed ship manufacturer has worked closely with the Wayfarers Club over the years to fine-tune ship design and performance to allow for more thorough assistance protocol, more flexible support functionality, and speedier response and repair times based on pilot feedback.

The Aegis Vulcan embodies this collaborative design philosophy, providing multiple remote-controlled support functions in a single pilot-friendly ship. Long known as the backbone of The Club's emergency assistance program, members in distress are serviced by Vulcans every day, in every corner of the 'verse.





## REFUEL

Over 50% of UWC distress beacons are sent by pilots in need of refueling. Hey, we've all been there - pushing the gauge under the line, counting on that Cry-Astro station that never comes. Whether you're a pro hauler on a tight deadline or a disoriented tourist that made an ill-advised jump, the UWC has your back... and a spare tank of quantum fuel.

*"I had run into some unexpected delays getting through Customs in Corel and making my drop on time was looking more and more impossible with every second that ticked by. Crusader Industries runs a very tight ship, so to speak, and I couldn't afford another flag on my record, so I was a little desperate. As soon as I cleared the checkpoint, I charted what was supposed to be a foolproof shortcut to Stanton through Taranis. Unfortunately, I overshot Taranis III and ended up stranded somewhere in the system with an empty quantum tank and no fuel stations in range. Foolproof indeed. Luckily the friendly folks at Dogwood '73 (one of Taranis' UWC certified associate clubs) picked up my beacon, dispatched a Vulcan immediately, and had me refueled and on my way. I ended up making it to Crusader with a few ticks to spare, all thanks to the UWC."*

Ramona Vasquez  
Kedsu Reef, Hadrian System

## REPAIR

Any number of factors could lead to a damaged ship, from run-of-the-mill space debris, to dogfighting, to colliding with other vessels, and in all conceivable cases, the UWC has your back. Trust us when we say we've seen it all, and fixed it twice. Simple repairs are the bread and butter of Vulcan pilots, and a specialty of their BARD drones, so sit back, relax and we'll have you back on your way with speed, efficiency, and most importantly - a smile.

*"Last year we took the kids to Croshaw to see the aurora, check out the quirky art scene and take in some winter sports on Vann. It was a great trip, but our route back to the jump point to Sol took us through the outskirts of the Daedalus asteroid cluster, where some random debris took out three of our four main thrusters. The kids were worried we'd be stranded for days, but our distress beacon was picked up by the UWC and they had a ship dispatched in no time. Not only did the pilot get our 600i back up and running in mere hours, he was super nice and the kids thought the drones were cooler than anything we saw on vacation. Thanks, United Wayfarers!"*

Meran Zieser  
Port Renatus, Mars, Sol System





## REARM

The UWC doesn't shy away from combat support. When the action gets heavy, the Vulcan thrives, thanks to a comprehensive weapons package and defense system. With its roots in the UEE Navy, the ship's sturdy design, robust shields, and dual turrets assure that the job gets done every time.

*"We were out on a standard patrol, just doing our thing, and we catch a handful of outlaw ships on the scan. I lock on to this real greasy dodger - he's bobbing and feinting like he's got a death wish - and I end up tailing him into the asteroid field. So there I am, suddenly cut off from my squad with this psycho looking to smoke me, and I realize that the old Sawbuck is running low on ammo. None of the boys are responding, so I shoot out a beacon and push deeper into the belt, trying to put some rock between my Stalker and this wild bogey. Of course, I'm thinking there's no way anyone shows up before I get blasted halfway to Branaugh III, but I'll be damned if a UWC Vulcan didn't make the scene just in the nick of time. That pilot braved asteroids and enemy fire to top off my repeater and get me back in the fight. The Club is a true boon to any Militia and the Dragoons fly with confidence knowing that the UWC has our backs."*

Rhen Vh'az  
Ne'er, Branaugh II, Branaugh System

## ONBOARD KIT

The Vulcan is as intuitive and pilot-friendly as it is scrappy and dependable, with a compact, efficient interior layout:

The cockpit contains two support stations in addition to the pilot seat, allowing for additional crew members to take control of the Vulcan's BARD drones, turrets and engineering functions.

A rear cargo hold is capable of carrying 12 SCU worth of supplies and materials for use in helping ships in various forms of distress.

The Vulcan even comes with basic living quarters, providing the crew with enough creature comforts to make life a little easier in the deep reaches of space.

The ship has been designed to maximize functionality and minimize nonessentials without sacrificing amenities. This enables our pilots and techs to continually provide assistance with the zeal and efficiency that the UWC has become known for, even on long hauls.

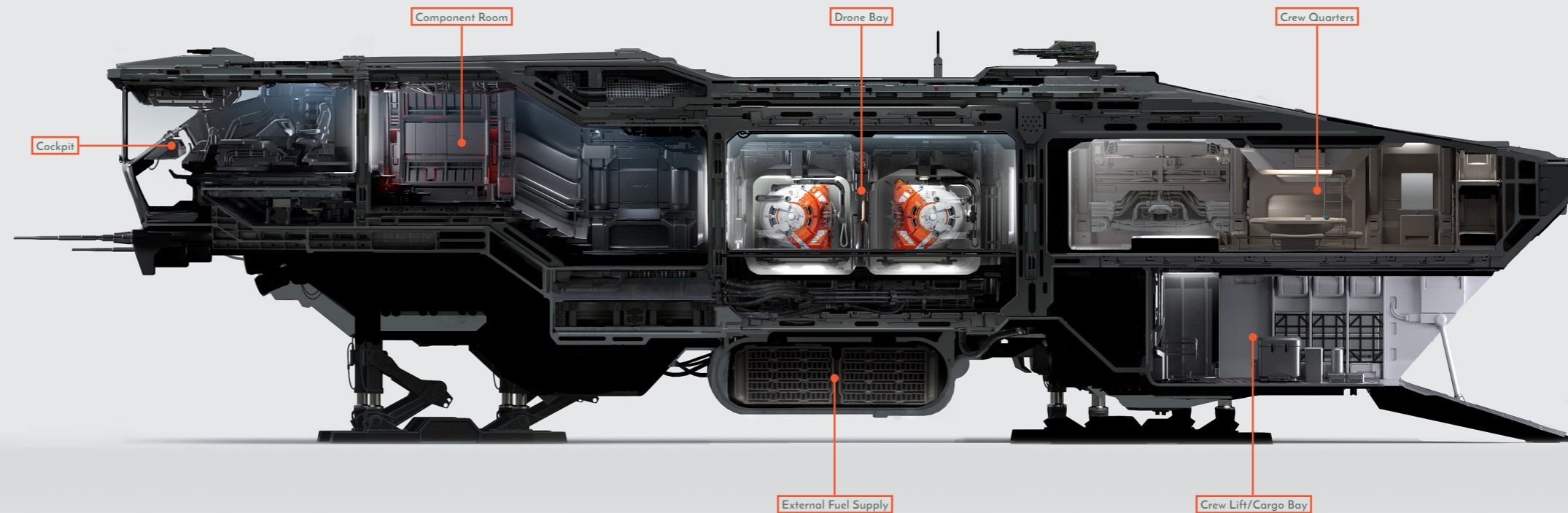

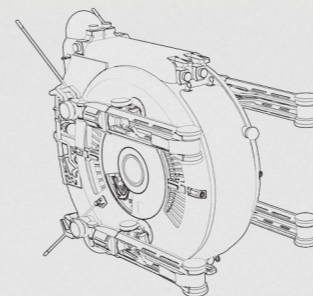
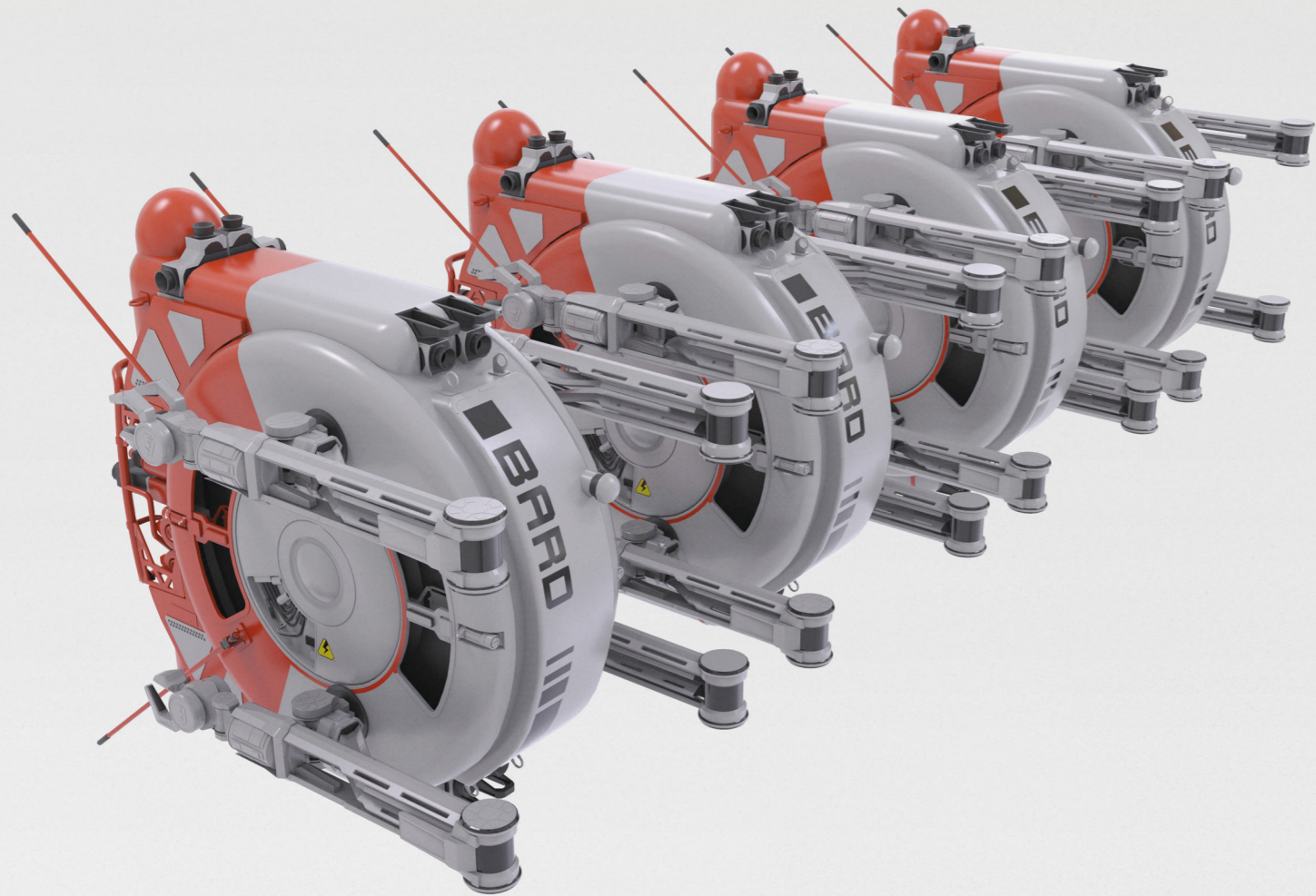

**STOWED**

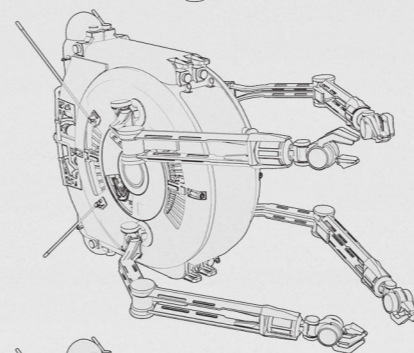

**MAINTAINING**

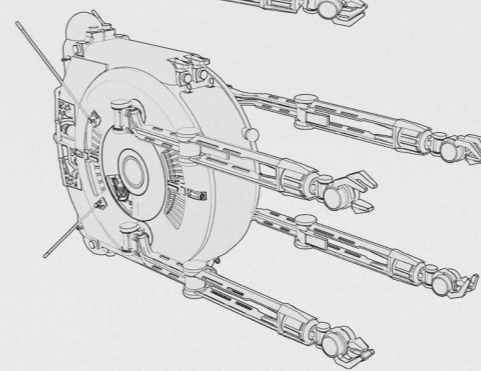

**HAULING**

## BARD

Commonly seen assisting repair ships throughout the 'verse, Saga Datasystems' Basic Articulated Repair Drone (BARD) can be assigned to execute any number of operations from simple repairs and refueling to tug functions and the manipulation of debris and cargo containers. It's because of this deftness in performing remote tasks in and around ships and stations that Aegis has relied on the BARD for more than 50 years.

All of our Vulcans come factory equipped with four BARDs, enabling UWC agents to perform several operations at once, without ever leaving the comfort of their ship.

Vulcan pilots generally consider their BARDs an extension of not only their ship, but themselves.



## ENDURING PARTNERS

The UWC was born as a result of the Project Far Star initiative and the general lack of safety and support for the rapidly growing base of pilots blazing new territory. The fleet employed by the early Wayfarers Clubs was a rag-tag, motley armada to say the least, made up mostly of heavily modified freight clippers, medium fighters and exploration vessels.

By the 26th Century, that all changed. After quickly expanding its reach and enjoying a burgeoning presence in the central UEE systems, the UWC was offered several long-term government support contracts. Thanks to this newfound legitimacy, they were able to court several of the prominent ship manufacturers of the time to contract dedicated repair ship designs. That's where Aegis Dynamics came into the mix.

The Vulcan's legacy goes back almost as far, debuting in 2594 as Aegis' newest Naval combat relief vessel. Over the years, the UWC and its agents and techs have worked closely with Aegis engineers to refine the Vulcan, resulting in what we have today - a versatile, scrappy support ship, capable of administering assistance, even under the direst of circumstances.



## MAKING A DIFFERENCE

ANNUAL DISTRESS BEACON ANALYSIS

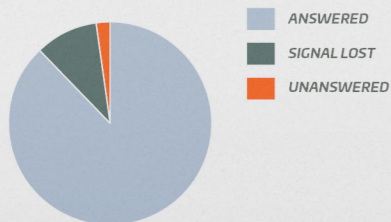

ANNUAL CIVIC IMPACT

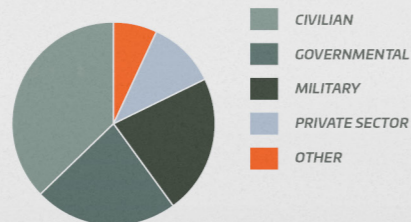

NETWORK BIAS

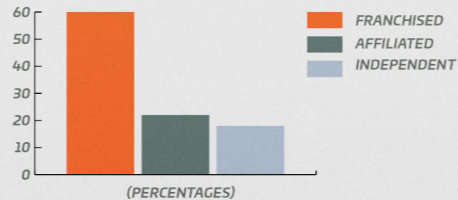

RESPONSE CLASSIFICATIONS

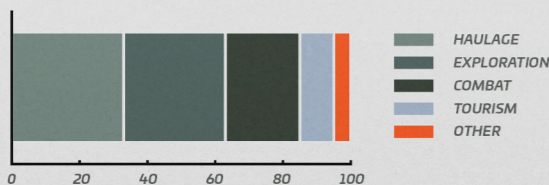

UNITED WAYFARERS CLUB EXPANSION

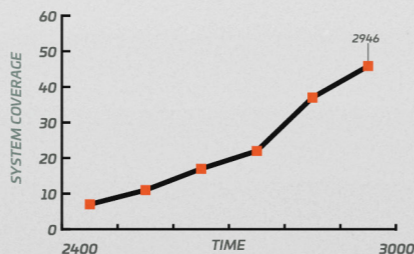

Results featured are from the 2946 Wayfarer's Guild survey; figures are averaged across all regions that responded. Average local sampling error +/- 5% confidence interval.



## OUR HISTORY:

Back in the 25th century, the government incentivized the discovery/colonization of new planets and systems with the Project Far Star initiative, but did very little to lend official support to pilots engaging in the movement in the fringe systems. Tavis "Doc" McGill, a mechanic and aspiring explorer, noticed this.

In 2473, McGill, acting president of the Selene Starship Club, proposed an alliance with three other local Flying Clubs (the New Corvo Quantum Club, the Starfarers Club of Vega, and the Aremis Fringe Runners) to form the original Wayfarers Club. The original purpose was to aid each other, allies and friendlies while flying in-system and support exploration efforts by creating a network of pilots willing to assist one another based on their specific ships and skillsets.

Eventually the concept expanded, first bringing other Vega System clubs into the fold and eventually incorporating Flying Clubs from other systems, changing the name of the organization to the United Wayfarers Club. The original

Wayfarer's Club became the Wayfarers Club of Vega, with other regional clubs adopting the same, or similar, naming convention (i.e. Wayfarers Club - Stanton System)

During the Messer era, the UWC was heavily tied to the Military, offering support (and sometimes combat-related) services in war time, and thus also became almost synonymous with Aegis Dynamics. The early Vulcan models and their like became the go-to ships for UWC support and assistance pilots. The club, however, became critical of Messer's tactics relatively early, and managed to cut formal ties with the military by the early 2600s, focusing more on local non-military Government contracts.

Today, the UWC (colloquially referred to as the "you-dub", the "dub-see" or oftentimes simply "the Club") has become a predominantly commercial venture, and a trusted resource for Citizens and civilians alike, providing relatively fast and convenient emergency assistance and support throughout the 'verse.



IN ASSOCIATION WITH



© 2018 Cloud Imperium Games Corporation and Roberts Space Industries Corp. and Cloud Imperium Games UK, Ltd and Roberts Space Industries International Ltd.

Star Citizen® and Roberts Space Industries® are registered trademarks of Cloud Imperium Games Corporation.

The vehicle depicted herein is undergoing concept and design as of the release of this publication. Specifications and appearance are subject to revision during development.