

ARGO
ASTRONAUTICS

SRV



The logo for SRV, with 'S' in orange and 'RV' in white.

LEGACY OF DEPENDABILITY

All ships break down. No make, model, or manufacturer is immune, no matter how well-made, well-tested, or well thought of. Eventually, every pilot can count on finding themselves stranded. Luckily, they can also count on the ARGO SRV.

For over seven centuries, Argo Astronautics has prided itself on getting the people and goods of the UEE where they need to be. That includes towing incapacitated vehicles and their crews to safety, wherever they may lie. That's what the SRV does. And it does it well.

In these often-unpredictable times, ARGO stands strong as a monolith of stability, delivering peace-of-mind through a no-nonsense approach to ship design. Refined and purposeful, ARGO ships feature only what's needed and little else. But that's the point. The SRV proudly continues this legacy, providing industrial solutions with a laser-focus on functionality, efficiency, and durability.

SRV

ARGO
ASTRONAUTICS

IN FOR THE LONG HAUL

Designed from the off as a dedicated tug, the SRV utilizes the patented MaxTraction tractor plate and integrated ArmAssist system to deliver unparalleled efficiency and usability. This innovative configuration, coupled with the rugged reliability of ARGO engineering, makes the SRV a perennial favorite of recovery workers, cargo haulers, megacorps, and the UEE military. Ask any pilot that's ever been stranded and, chances are, they'll regale you with a tale of the ARGO SRV that pulled them to safety.



SRV



READY FOR ANYTHING

The SRV is built to handle whatever you can throw at it. From simple freight and cargo towing to harrowing search-and-rescue operations, its ultra-durable armor and heavy-duty shields ensure it holds its own when the situation gets hairy. The SRV's proprietary tractor rig accommodates a variety of situations when flying solo along with multi-tractor coordination for bigger jobs, making it the most effective and flexible tug available on the civilian market.



SRV

HEAVY LIFTER

The SRV may have made its name rescuing incapacitated vessels from the vastness of space, but its talents as a tugship don't stop there. The inventive tractor rig is equally well-suited to transporting large-scale cargo, so why waste resources on a bulky multicrew hauler when you can lug just as much freight solo with an SRV?



SRV



ONBOARD ACCOMMODATIONS

The SRV's roomy interior offers more than enough space for you and your recovered passengers. Outfitted with full bathroom facilities, cozy jump-style seating, a multi-use table surface, and ample storage for food and personal effects, it's a welcome comfort to stranded pilots.

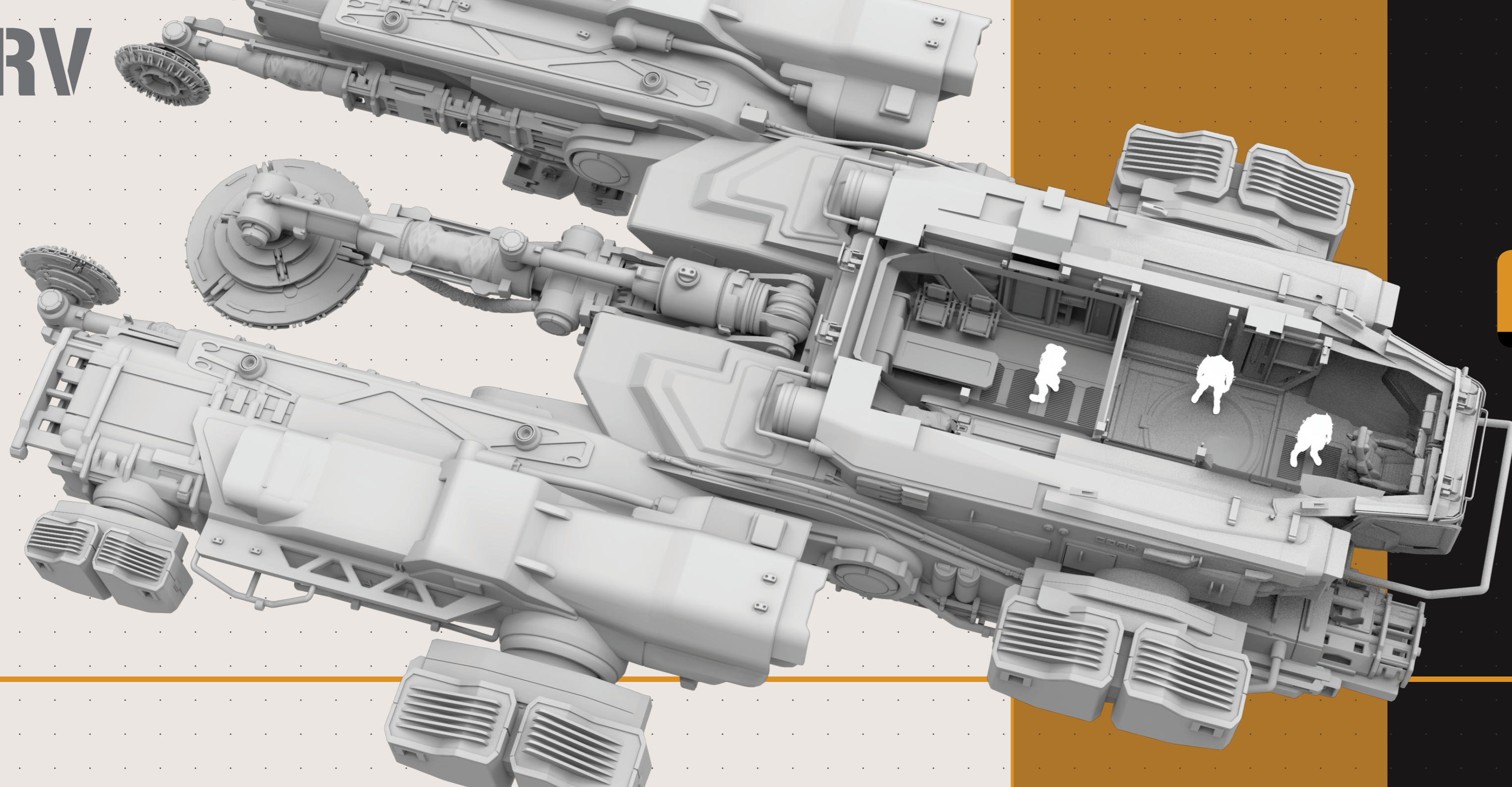

ARMASSIST TRACTOR RIG

Fully-integrated arm rig grants peerless control and precision. Alongside the custom MaxTraction plate, it enables the ship to effortlessly handle large and unwieldy payloads.

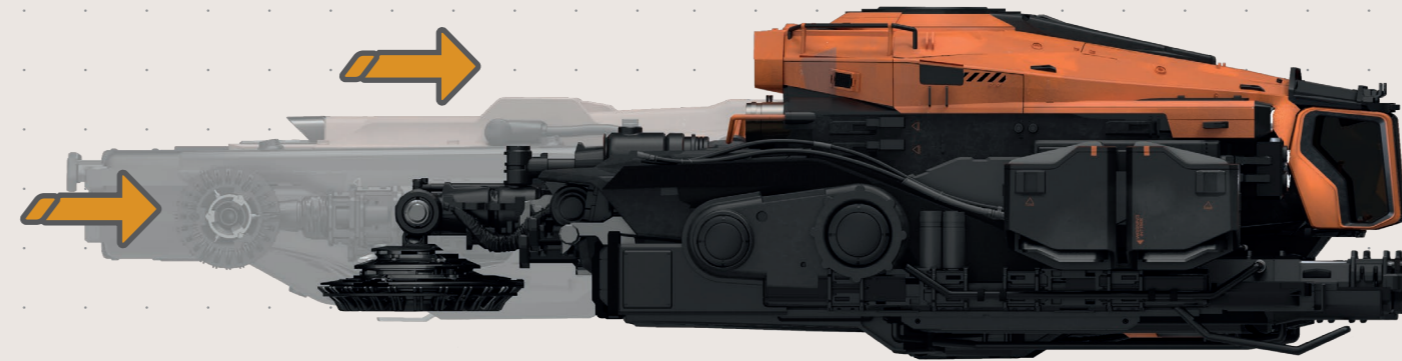
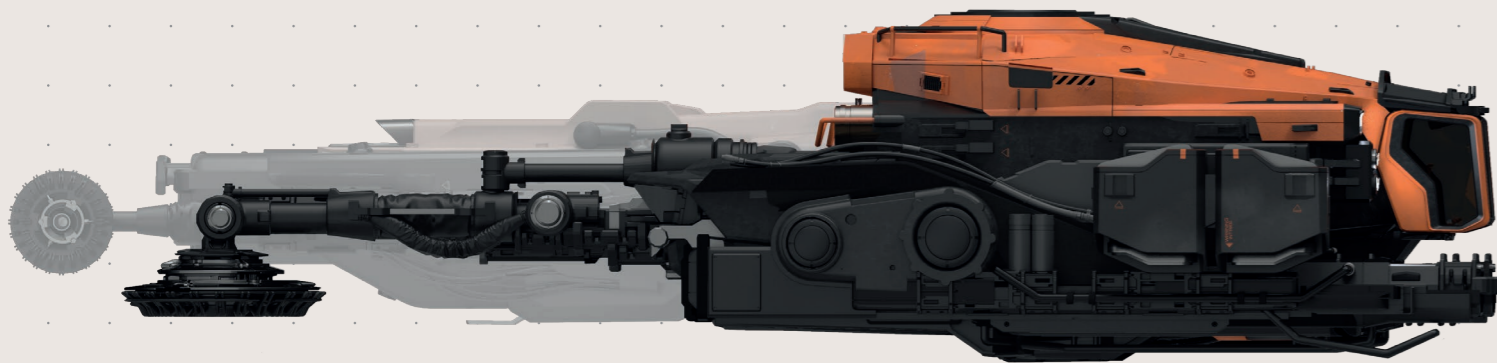

Lateral compression allows for the lifting and hauling of large objects from above with amazing accuracy and maneuverability. This configuration also facilitates overhead team and formation towing.

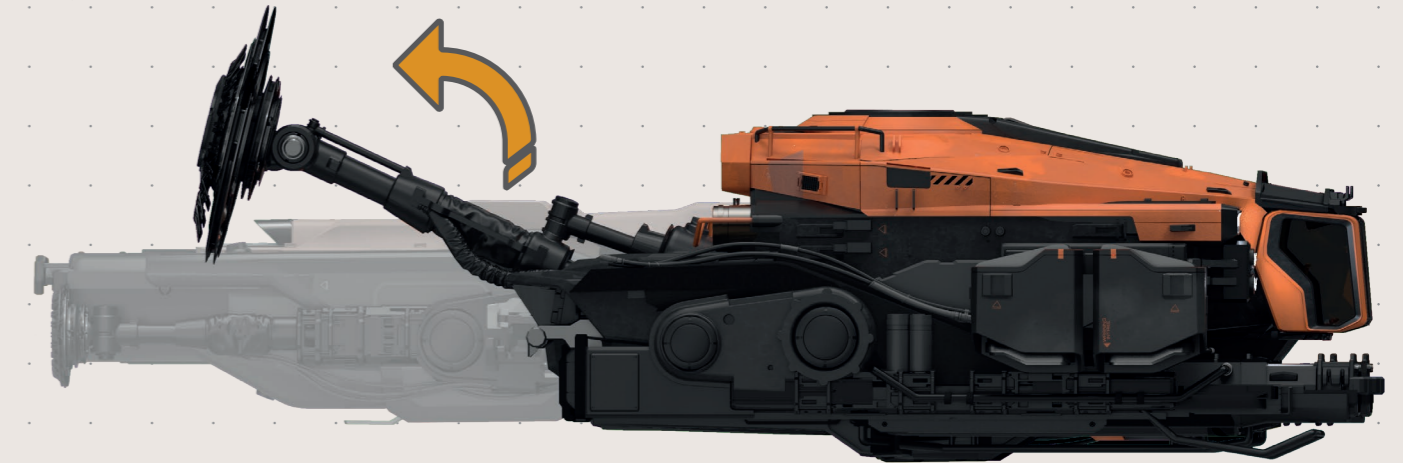

Rear parallel-flanking enables maximum stability in even the most adverse conditions. Pilots and customers alike can rest easy in the knowledge that their cargo is safe in the capable arm of an SRV.

MAXTRACTION BULLOCK

ARGO's custom-designed tractor plate was developed specifically for the SRV. Its unique specifications include a hydraulic boom and bespoke gimbal mount for maximum flexibility.

Working in concert with the SRV's innovative arm rig and utilizing beam strength uncommon for a unit of its size, the Bullock packs unprecedented towing power and versatility into a relatively small package.

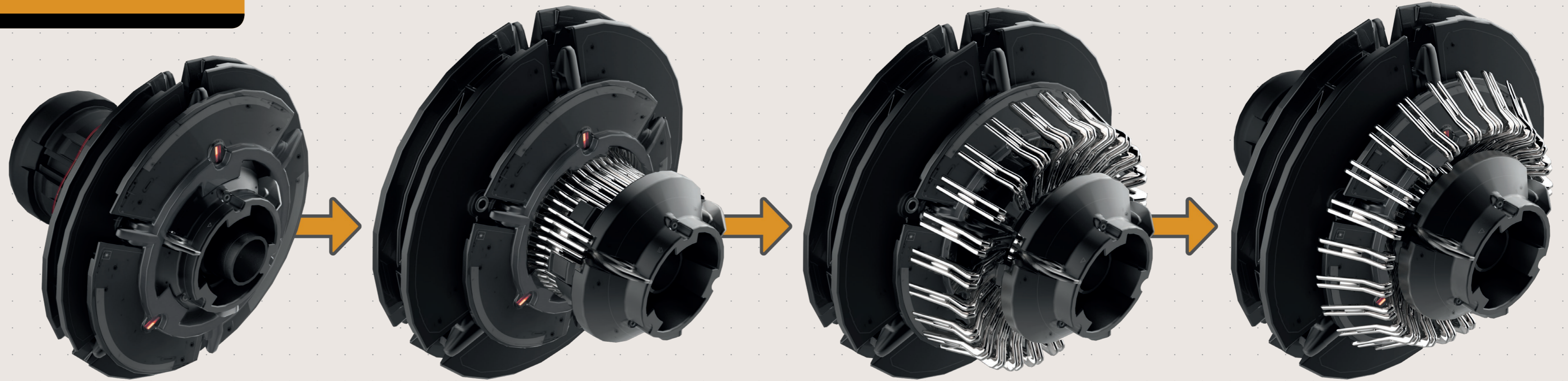

SRV

DIMENSIONS
L 28.5m W 19.5m H 8.7m

MASS
231,680kg

FLIGHT SPEED
200m/s

CREW
1

PASSENGERS
4

CARGO
10 SCU

MOUNTS
1x S3 Utility Mount Tractor Beam

COUNTERMEASURES
Flare/Chaff Launcher

QUANTUM DRIVE
1x S2

JUMP DRIVE
1x S2

ARMOUR
1x S2

SHIELDS
1x S2

BOW

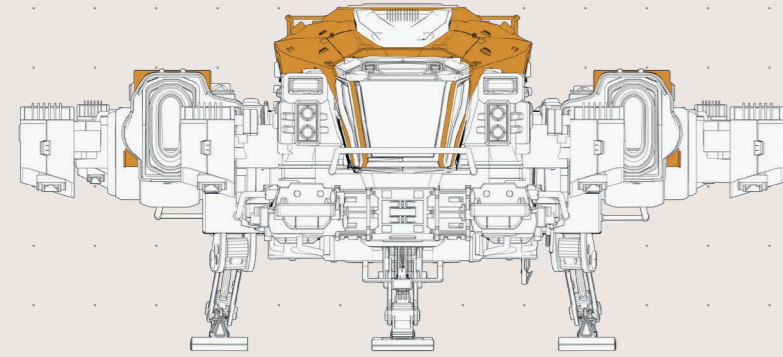

STERN

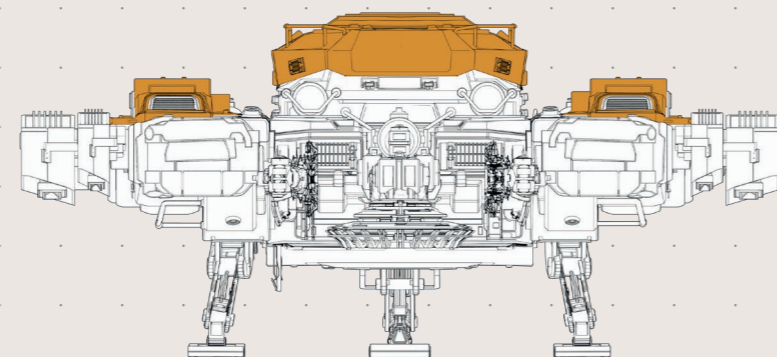

DORSAL

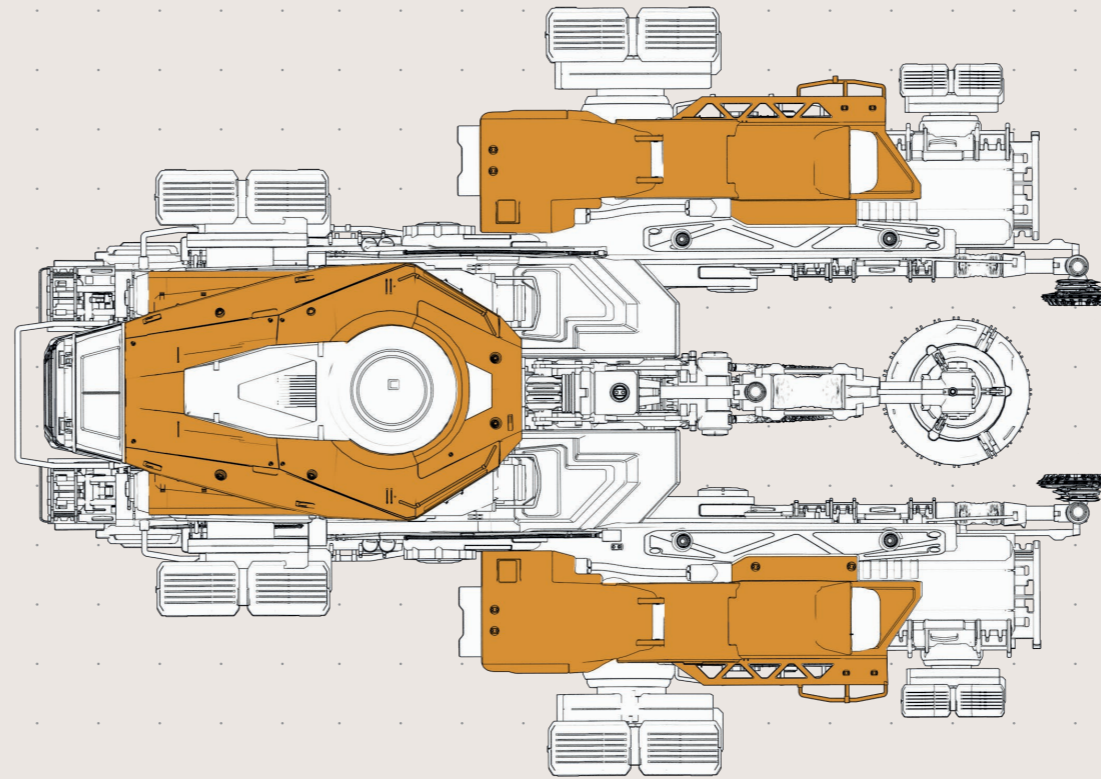

VENTRAL

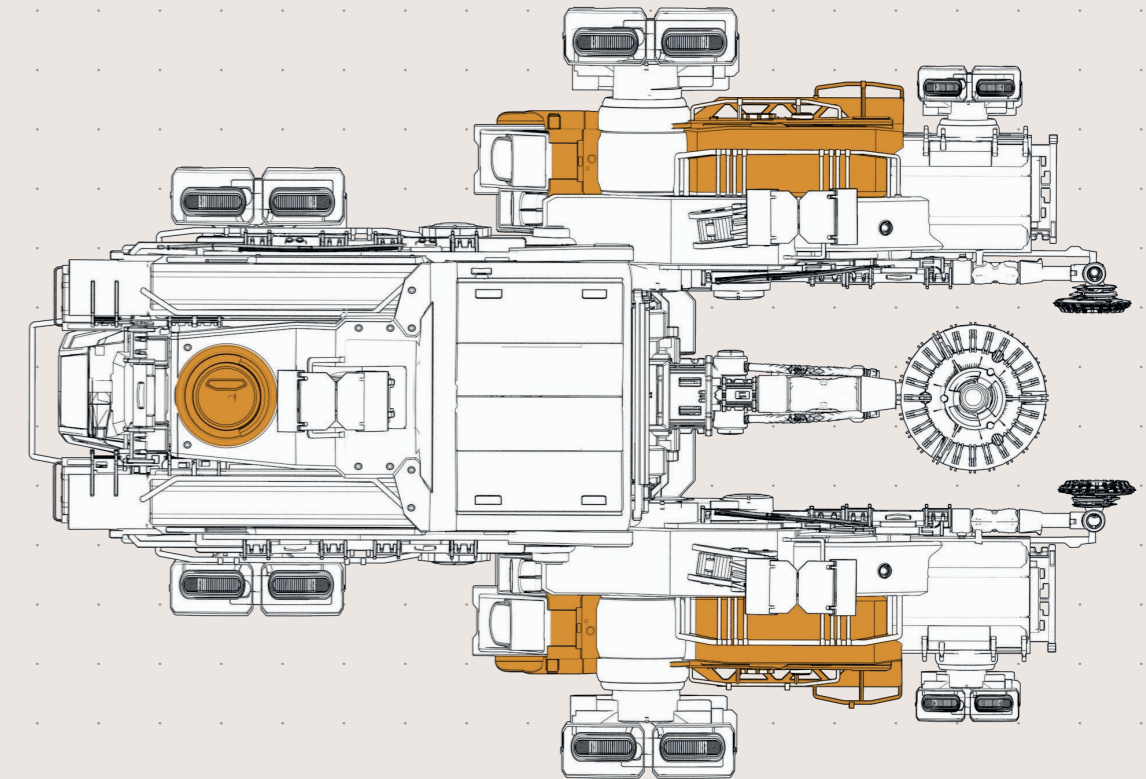

LATERAL

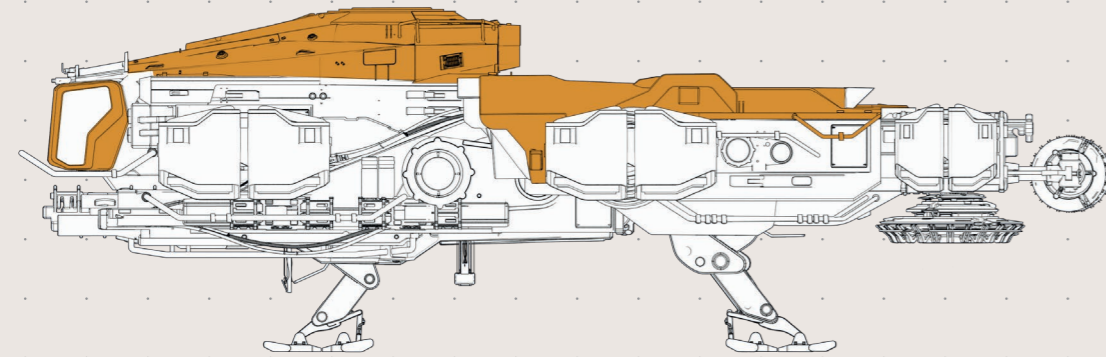

SRV

TRIED AND TRUE

The United Wayfarers Club (UWC) has depended on ARGO ships for generations, with the SRV a diligent constant throughout their shared history, saving countless ships and lives along the way. This is why the UWC remains a proud partner of Argo Astronautics and champion of the SRV.

The Club is always seeking reliable SRV pilots to join their ever-growing network of affiliates. What do you say? Get behind the stick of an ARGO SRV and make a difference today!

The UWC & Argo Astronautics

Partners in Perseverance

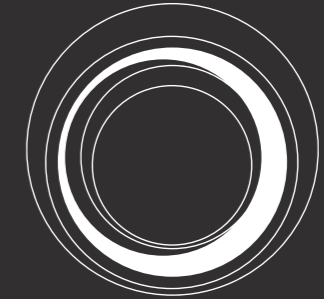

A R G O
ASTRONAUTICS



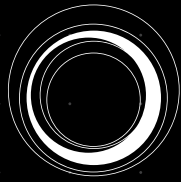

ARGO
ASTRONAUTICS

The models featured in this publication are approved for use in the UEE. Some items of equipment are available as extra-cost options only. Specifications correct at date of publish. For information on standard and optional equipment, please consult your local Dealer. Specifications, features and appearance are subject to revision during development.

© 2019 Cloud Imperium Rights LLC and Cloud Imperium Rights Ltd. Star Citizen® and Roberts Space Industries® are registered trademarks of Cloud Imperium Rights LLC